

TOPCOM[®]

BALANCE



USER GUIDE

V1.0 - 06/08



Important

To use 'Caller ID' (display caller), this service has to be activated on your phone line. Normally you need a separate subscription from your telephone company to activate this function. If you don't have the Caller ID function on your phone line, the incoming telephone numbers will NOT be shown on the display of your telephone.

The features described in this manual are published with reservation to modifications.

To be connected to the public analogue telephone network.

The CE symbol indicates that the unit complies with the essential requirements of the R&TTE directive.

This product is in compliance with the essential requirements and other relevant provisions of the R&TTE directive 1999/5/EC. The Declaration of conformity can be found on:

<http://www.topcom.net/cedeclarations.asp>



This product works with rechargeable batteries only. If you put non-rechargeable batteries in the handset and place it on the base, the handset will be damaged and this is NOT covered under the warranty conditions.

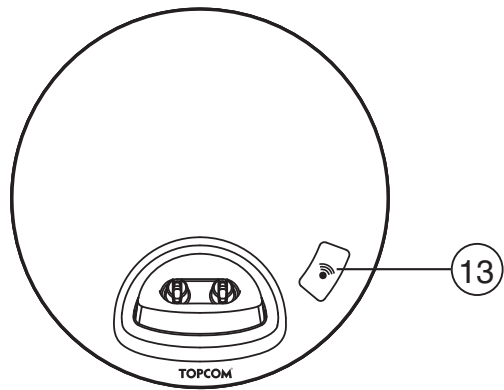
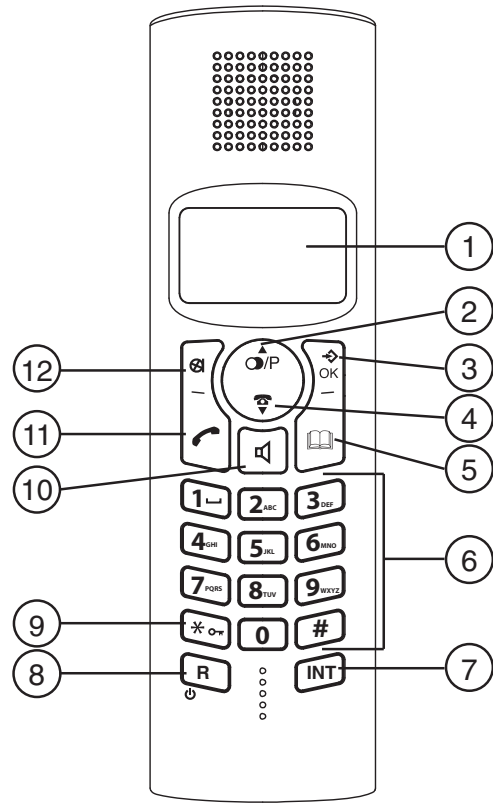

1	Safety instructions	5
2	Getting started	5
2.1	How to use this user guide.....	5
2.2	Installing the base	6
2.3	Installing the handset.....	6
2.4	Keys / LED's	7
2.5	Symbols	8
2.6	Navigating the menu.....	8
2.7	Menu overview	8
3	Using the telephone.....	9
3.1	Switching the handset on/off.....	9
3.2	Changing the menu language	9
3.3	Receiving a telephone call.....	9
3.4	Making an external telephone call.....	9
3.5	Making an internal telephone call	10
3.6	Internal call transfer.....	10
3.7	Conference call	10
3.8	Handsfree mode.....	10
3.9	Speaker volume during call	10
3.10	Display of call duration	11
3.11	Microphone mute.....	11
3.12	Pause key	11
3.13	Locating a handset (Paging function).....	11
3.14	Redial memory	11
3.15	Using the alphanumerical keypad	11
4	Phonebook	12
4.1	To add an entry into the phonebook	12
4.2	To dial an entry from the phonebook	12
4.3	To modify a name and number.....	12
4.4	Delete an entry from the phonebook	13
5	Caller Identification.....	13
6	Personalize the handset	14
6.1	Adjusting the ring volume	14
6.2	Choosing the ring melody	15
6.3	Activation/deactivation of beeps	15
6.4	Handset name	15
6.5	Automatic answer.....	16
6.6	Reset the handset	16
6.7	Keypad lock.....	17
6.8	Setting the time.....	17
6.9	Setting the alarm.....	17
7	Base settings	17
7.1	Adjusting the ring volume	17
7.2	Choosing the ring melody	17
7.3	Changing the PIN code.....	18
7.4	Setting the dialing mode.....	18
7.5	Flash time duration	18
8	Managing multiple handsets.....	18
8.1	Adding a new handset	18
8.2	Removing a handset	19

8.3	Setting up a handset on another base.....	19
8.4	Selecting a base	20
9	SMS	20
9.1	How to write an SMS	20
9.2	Sending an SMS	20
9.3	Read and view the list of received messages (Inbox).....	21
9.4	Multiple users	21
9.5	SMS settings.....	22
10	Troubleshooting	24
11	Technical dataTechnical characteristics.....	24
12	Topcom Warranty	25
12.1	Warranty period.....	25
12.2	Warranty handling	25
12.3	Warranty exclusions	25
13	Disposal of the device (environment).....	25
14	Cleaning	25

English

1 Safety instructions

- Only use the charger plug supplied. Do not use other chargers as this may damage the battery cells.
- Only insert rechargeable batteries of the same type. Never use ordinary, non-rechargeable batteries. Insert rechargeable batteries so they connect to the right poles (indicated in the battery compartment of the handset).
- Do not touch the charger and plug contacts with sharp or metal objects.
- The operations of some medical devices may be affected.
- The handset may cause an unpleasant buzzing sound in hearing aids.
- Do not place the basic unit in a damp room or at a distance of less than 1.5 m away from a water source. Keep water away from the handset.
- Do not use the telephone in environments where there is a risk of explosions.
- Dispose of the batteries and maintain the telephone in an environment-friendly manner.
- As this telephone cannot be used in case of a power cut, you should use a mains-independent telephone for emergency calls, e.g. a mobile phone.

2 Getting started

2.1 How to use this user guide

In this user guide, following method is used to clarify the instructions:



Key to press.

Text..... “DISPLAY”.



Text that appears on the display of the phone is shown in the right column between quotation marks.

2.2 Installing the base

- 1** Plug one end of the adaptor into the outlet and the other end into the adaptor jack on the bottom of the base.
- 2** Connect one end of the telephone cord with the wall phone jack and the other end to the bottom of the base.
- 3** Put the telephone- and AC power line cord in the base guides as shown on picture 2A.

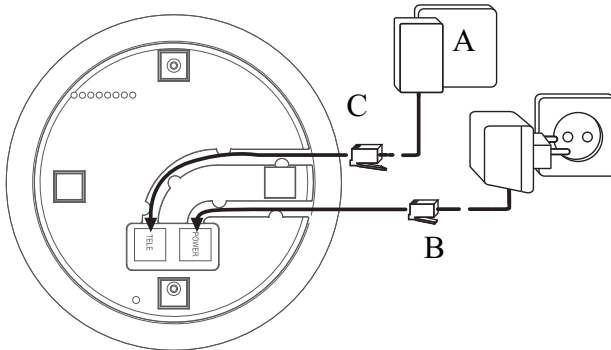

- 2A Back view of base -

A. Telephone wall outlet

B. Power cable

C. Telephone cord

2.3 Installing the handset

- 1** Open the battery compartment as shown on picture 2B.
- 2** Insert the batteries respecting the polarity (+ and -).
- 3** Close the battery compartment.
- 4** Leave the handset on the base unit for 20 hours.

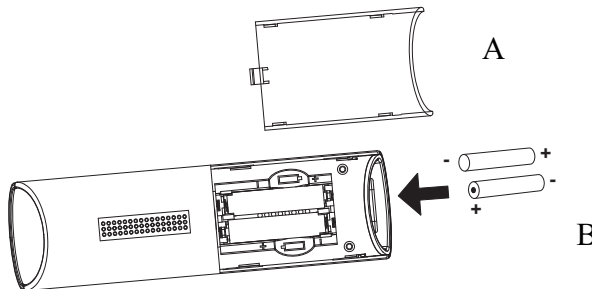

- 2B Back view of handset -

A. Cover

B. Rechargeable batteries



Before you use the telephone for the first time, you must first make sure the battery is charged for 20 hours. If you do not do this, the telephone will not work optimally.

2.4 Keys / LED's

Handset

1. Display
2. Redial / pause / up key
3. Menu / OK key
4. Call log / down key
5. Phonebook key
6. Alphanumeric keys
7. INT key
8. On / off / flash key
9. Keypad lock
10. Handsfree key
11. On-hook / off-hook key
12. Mute / delete / esc key

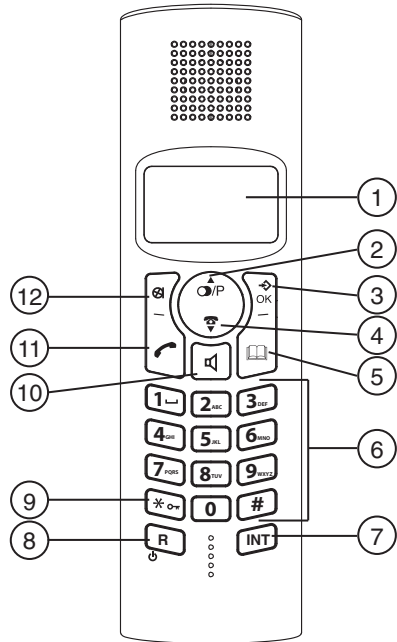

- 2C Handset -

Base

13. Paging key

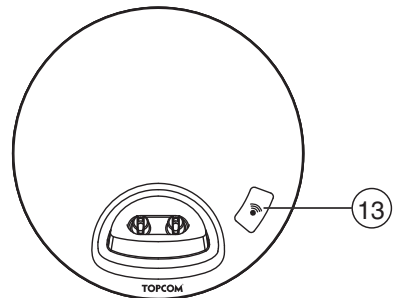

- 2D Base -

Display





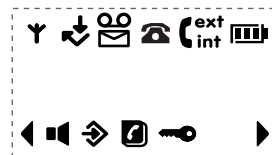











In standby mode, the display shows the time and the handset number:

12-05 HS1







- 2E Display -

2.5 Symbols

	Off hook; you are online		Handset keypad locked
ext	External call		You are in the phonebook
int	Internal call		Battery low
	New numbers in call list		Battery medium
	Answered call		Battery full
	Unanswered call		Battery empty
	Your are in the menu		New voice mail
	Handsfree		Handset within base range
	Indicates that the displayed number is longer than the screen (12 digits)		The antenna flashes when the handset is not registered on the base
	New SMS message		

2.6 Navigating the menu

The Topcom Balance has a menu system which is easy to use. Each menu leads to a list of options. The menu map is shown on the following paragraph.

- /OK **1** When the handset is switched on and in standby, press the menu key to open the main menu.
-  **2** Scroll to the desired menu option. The menu options scroll in a loop (you return to the first after the last).
- /OK **3** Press the OK key to view further options or to confirm the setting displayed.
-  | Press the delete key to return to the previous level in the menu.



2.7 Menu overview

Menu	Submenu items
PHONEBOOK	ADD ENTRY MODIFY ENTRY DELETE ENTRY
SMS	INBOX PERSONAL SMS WRITE DELETE ALL SMS SETTINGS
SETUP	BASE VOLUME BASE MELODY DEL HANDSET PIN CODE DIAL MODE DEFAULT







Menu	Submenu items
HANDSET	BEEP INT RING VOL EXT RING VOL INT MELODY EXT MELODY AUTO ANSWER NAME LANGUAGE KEYLOCK?
DATE - TIME	DATE SET CLOCK SET ALARM SET
REGISTER	SELECT BASE REG BASE

3 Using the telephone

3.1 Switching the handset on/off



-  **1** Press and hold the on/off key for 8 seconds on the handset. The handset will search the base.
-  **2** Press and hold the on/off key for 8 seconds. The display will go off.

3.2 Changing the menu language

-  **1** Enter the menu
-   **2** Select “HANDSET” and confirm.
-   **3** Select “LANGUAGE” and confirm.
-   **4** Select a language and confirm.





3.3 Receiving a telephone call

To take the call:

-  **1** Press the off-hook key.
OR
Lift the handset off its base if you have activated “Automatic answer”.
(See “6.5 Automatic answer”)
You are connected to your correspondent.
-  **2** Press the on-hook key to hang up or put the handset back on the base.

3.4 Making an external telephone call

Direct dialing

-  **1** Press the off-hook key to start the call.
-  **2** Dial the telephone number.
-  **3** Press the on-hook key to hang up or put the handset back on the base.
-  To correct a number use the delete key to delete an entered digit.

Pre-dialing**1** Dial the telephone number.**2** Press the off-hook key to start the call.**3** Press the on-hook key to hang up or put the handset back on the base.**3.5 Making an internal telephone call**

INT

1 Press the internal call key.**2** Enter the number of the internal handset (1 to 5).**3** Press the on-hook key to hang up or put the handset back on the base.**3.6 Internal call transfer**

Transfer an external call to an other handset.

INT

1 Press the internal call key.**2** Enter the number of the internal handset (1 to 5), the external caller is put on hold.**3** When the other handset picks up, press the on-hook key to hang up and transfer the call.

INT

If the internal correspondent does not pick-up, press the Internal call key again to reconnect to the external caller on line.

**4** Press the on-hook key to hang up or put the handset back on the base.**3.7 Conference call**

Only possible when more then one handset are registered to the base!

You can converse simultaneously with an internal correspondent and an external correspondent.

During an external call:

INT

1 Press the internal call key.**2** Enter the number of the internal handset (1 to 5).

#

3 When the other handset picks up, press and hold the ' #' key.

INT

If the internal correspondent does not pick-up, press the Internal call key again to reconnect to the external caller on line.

**4** Press the on-hook key to hang up or put the handset back on the base.**3.8 Handsfree mode**

You can speak with your correspondent without picking up the handset.

**1** Press the handsfree key during a call to activate or deactivate the handsfree mode.**3.9 Speaker volume during call****1** During a conversation, press the up or down key to change the volume accordingly.*The handsfree volume is also adjusted together with the receiver in the handset as above described.*

3.10 Display of call duration

The call duration is displayed after 15 seconds, in minutes - seconds.
At the end of each call, the total call duration is displayed for 5 seconds.

3.11 Microphone mute

It is possible to mute the microphone during a conversation.



1 Press the mute key. You can talk freely without being heard by the calling party.

“MUTE” is displayed.



2 Press the mute key again to return to normal mode.

3.12 Pause key

When dialing a number you can add a pause between two digits:



1 Press the redial/pause key for 2 seconds.

3.13 Locating a handset (Paging function)



1 Press the paging key on the base.

All handsets registered with the base will ring.



2 Press any key on the handset to stop the ringing.

3.14 Redial memory

You can redial up to 10 of the last numbers called. If you have stored a name in the phonebook to go with the number, the name will be displayed instead.



1 Press the redial key.



2 Select a number. If the number is in the phonebook, the name will be shown.



When the name is displayed, you can toggle between the name and the number by pressing the OK key!



3 Press the off-hook key to start the call.



4 Press the on-hook key to return to standby.

3.15 Using the alphanumeric keypad

With your telephone, you can also enter alphanumeric characters. This is useful for entering a name into the phonebook, giving a name to the handset, ...

To select a letter, press the corresponding key as many times as necessary.

For example, to select an ‘A’, press ‘2’ once. To select a ‘B’, press ‘2’ twice and so on.

To select ‘A’ and then ‘B’ consecutively, press ‘2’ once, wait until the cursor moves on to the next character, then press ‘2’ twice.



Press ‘1’ to select a space.



Press the delete key to delete a character.

The keypad characters are as follows:















Key	First press	Second press	Third press	Fourth press	Fifth press
1	space	-	1		
2	A	B	C	2	
3	D	E	F	3	
4	G	H	I	4	
5	J	K	L	5	
6	M	N	O	6	
7	P	Q	R	S	7
8	T	U	V	8	
9	W	X	Y	Z	9
0	0				

4 Phonebook







Each handset can store up to 50 telephone numbers and names. Names can be up to 12 characters long and numbers up to 20 digits.

To enter alphanumerical characters, refer to the section “3.15 Using the alphanumerical keypad”.











4.1 To add an entry into the phonebook





- | | |
|---|---|
|  /OK | 1 Enter the menu. |
|    /OK | 2 Select “PHONEBOOK” and confirm. |
|    /OK | 3 Select “ADD ENTRY” and confirm. |
|   /OK | 4 Enter the name and confirm. |
|  | Press the phonebook key to exit the menu without taking any modifications into account. |
|   /OK | 5 Enter the number and confirm. |
|    /OK | 6 Select a ring melody (1-10) and confirm. |

4.2 To dial an entry from the phonebook









- | | |
|---|---|
|  | 1 Press the phonebook key. |
|   | 2 Select a name or enter the first letter of the name. (The list scrolls in alphabetical order.) |
|  /OK | Press the OK key if you first like to see the telephone number. |
|  /OK | If the telephone number is longer than 12 digits, press the OK key again to see the complete number. |
|  | 3 Press the off-hook key to start the call. |
|  | 4 Press the on-hook key to hang up or put the handset back on the base. |

4.3 To modify a name and number

- | | |
|---|---|
|  /OK | 1 Enter the menu. |
|    /OK | 2 Select “PHONEBOOK” and confirm. |
|    /OK | 3 Select “MODIFY ENTRY” and confirm. |
|    /OK | 4 Select the name to modify and confirm. |

-   **5** Delete the unwanted characters and enter the new name. Confirm.
-  **6** Enter the new number and confirm.
-   **7** Select a ring melody (1-10) and confirm.

4.4 Delete an entry from the phonebook

-  **1** Enter the menu
-   **2** Select "PHONEBOOK" and confirm.
-   **3** Select "DELETE ENTRY" and confirm.
-   **4** Select a name or enter the first letter of the name and confirm. "CONFIRM" appears on the display.
-   **5** Confirm or cancel.

5 Caller Identification



This service only works when you have a Caller ID/Clip subscription. Please contact your telephone company.







When you receive an external call, the telephone number of the caller appears on the handset display. The telephone can receive calls in both FSK and DTMF. You can also see his or her name if it is transmitted by the network. If the name is programmed in the phonebook, the name in the phonebook is displayed!

-  The caller identity is replaced by the call duration after 15 seconds in communication. It is still possible to display the caller's identity after this time by pressing the OK key repeatedly for the name and number.

The telephone can store 40 calls in a Call List (received and missed calls) that can be reviewed later. This function is only available if your are subscribed to the caller ID information. When the memory is full, the new calls automatically replace the oldest calls in the memory.

-  New or missed calls are signaled by a blinking icon on the display.

To consult the list of calls:

-  **1** Press the call log key.
 -  **2** Scroll through the calls. The callers names will be shown if the name is send by the network or is stored in the phonebook. If you are at the end of the list you will hear a beep tone.
- When  is shown, this call is been answered. When  is shown, the call is unanswered
-  **3** Press the OK key to see the telephone number.
 -  If the telephone number is longer then 12 digits, press the OK key again to see the complete number.
 -  **4** Press the OK key again to see the time and date when the call is received.



5 Press the OK key to add this entry to the phonebook if it's not already stored:
Press OK when "ADD" is shown on the display. Enter or modify the name and press OK. Enter or modify the telephonenumber and press OK. Select the melody (1-10) which will be heard when this number is calling by means of the up/down keys and press OK. The entry will be stored in the phonebook.



6 Press the off-hook key to call back a correspondent, when their telephone number or name are displayed.

You can delete each entry separately:



1 Scroll to the call you want to delete and delete.
"DELETE" appears on the screen.



2 Confirm or cancel.

To delete all entries at ones:



1 Press the delete key long (2 seconds).
"DELETE ALL" appears on the screen.



2 Confirm or cancel.

6 Personalize the handset



Every programming is confirmed at the end by a double or single long beep. A double beep confirms the validation of your choice. A long beep signifies that the modification has not been taken into account.

6.1 Adjusting the ring volume

Handset ring volume internal/external calls

The handset ring volume for internal or external calls can be set separately. You can choose from 5 handset ringer volume levels and "OFF".



When the handset is inside the base, the base will not ring during incoming call. So when the handset ring volume is turned off and handset is inside the base, your phone will not ring anymore!



1 Enter the menu



2 Select "HANDSET" and confirm.



3 Select "INT RING VOL" to change the internal volume or "EXT RING VOL" to change the external volume and confirm.



4 Select a volume (1 to 5 or "OFF").



5 Confirm or return to the previous menu.

6.2 Choosing the ring melody

The base and each handset can ring with a different melody. The handsets can ring with a different melody according to whether the call is internal or external. You can choose from 10 different ring melodies:

- | | | |
|---------|----------|--|
| ↵/OK | 1 | Enter the menu |
| ▲▼ ↵/OK | 2 | Select "SETUP" and confirm. |
| ▲▼ ↵/OK | 3 | Select "HANDSET" and confirm. |
| ▲▼ ↵/OK | 4 | Select "INT MELODY" to change the internal melody or "EXT MELODY" to change the external melody and confirm. |
| ▲▼ | 5 | Select a melody (1 to 10). |
| ↵/OK ⊗ | 6 | Press the OK key to confirm or return to the previous menu. |

6.3 Activation/deactivation of beeps

The handsets can emit a beep tone when a key is pressed, when the batteries are low or when the handset is out of range.

Key pressed beep tone on/off

- | | | |
|---------|----------|---|
| ↵/OK | 1 | Enter the menu |
| ▲▼ ↵/OK | 2 | Select "HANDSET" and confirm. |
| ▲▼ ↵/OK | 3 | Select "BEEP" and confirm. |
| ▲▼ ↵/OK | 4 | Select "KEYTONE" and confirm. |
| ▲▼ ↵/OK | 5 | Select "ON" to activate or "OFF" to deactivate and confirm. |

Low battery

- | | | |
|---------|----------|---|
| ↵/OK | 1 | Enter the menu |
| ▲▼ ↵/OK | 2 | Select "HANDSET" and confirm. |
| ▲▼ ↵/OK | 3 | Select "BEEP" and confirm. |
| ▲▼ ↵/OK | 4 | Select "LOW BATTERY" and confirm. |
| ▲▼ ↵/OK | 5 | Select "ON" to activate or "OFF" to deactivate and confirm. |





Handset out of range

- | | | |
|---------|----------|---|
| ↵/OK | 1 | Enter the menu |
| ▲▼ ↵/OK | 2 | Select "HANDSET" and confirm. |
| ▲▼ ↵/OK | 3 | Select "BEEP" and confirm. |
| ▲▼ ↵/OK | 4 | Select "OUT RANGE" and confirm. |
| ▲▼ ↵/OK | 5 | Select "ON" to activate or "OFF" to deactivate and confirm. |

6.4 Handset name







You can change the name displayed on the handset (max. 9 characters). This function allows you to personalize each handset.

- | | | |
|---------|----------|-------------------------------|
| ↵/OK | 1 | Enter the menu |
| ▲▼ ↵/OK | 2 | Select "HANDSET" and confirm. |
| ▲▼ ↵/OK | 3 | Select "NAME" and confirm. |

-   **4** Enter the name you want and confirm.
-  **4** Press the delete key to delete a character. Press and hold the phonebook key to exit the menu without taking any modifications into account.
- 

6.5 Automatic answer







When there is a incoming call and the handset is on the base, the phone automatically takes the line when lifted. This is the default setting, but can be set off:

-  **1** Enter the menu
-   **2** Select "HANDSET" and confirm.
-   **3** Select "AUTO ANSWER" and confirm.
-   **4** Select "ON" to activate or "OFF" to deactivate and confirm.

6.6 Reset the handset

It is possible to return the phone to the original default configuration. This is the configuration which was installed when you first received the telephone.

To return to default settings:

-  **1** Enter the menu
-   **2** Select "SETUP" and confirm.
-   **3** Select "DEFAULT" and confirm.
-   **4** Enter the 4 digit PIN code (default =0000) and confirm.

Default parameters are:

Low battery beeps	On
Out of range warning beeps	Off
Key tone	On
Auto answer	On
Internal melody	1
Internal volume	3
External melody	3
External volume	3
Ear volume	3
Phonebook	Empty
Call log list	Empty
Redial list	Empty
PIN code	0000
Dial mode	DTMF
Keypad lock	Off



Returning to default settings will delete all entries in the phonebook and call log. The PIN code will also be reset to 0000.

6.7 Keypad lock

The keypad can be locked so that no settings can be changed or no telephone number can be dialed. The  icon will appear on the screen when keypad is locked.









Locking the keypad

- * | **1** Press and hold the ‘*’ key for 3 seconds. The keypad will be locked.













Unlock the keypad

- * | **1** Press any key, “PRESS *” will appear on the screen.
 * | **2** Press the ‘*’ key within 3 seconds.

6.8 Setting the time

- /OK | **1** Enter the menu
  | **2** Select “DATE - TIME” and confirm.
  | **3** Select “CLOCK SET” and confirm.
   | **4** Enter the time (24h format) and confirm.

6.9 Setting the alarm









- /OK | **1** Enter the menu
  | **2** Select “DATE - TIME” and confirm.
  | **3** Select “ALARM SET” and confirm.
  | **4** Select “ON” to turn on the alarm and confirm.
   | Enter the time (24h format) when the alarm must be activated and confirm.
 OR
  | Select “OFF” to turn off the alarm and confirm.

7 Base settings

7.1 Adjusting the ring volume









Base ring volume

You can choose from 5 ringer volume levels and “OFF”.

- /OK | **1** Enter the menu
  | **2** Select “SETUP” and confirm.
  | **3** Select “BASE VOLUME” and confirm.
 | **4** Select a volume (“OFF” or 1 to 5).
/OK  | **5** Confirm or return to the previous menu.

7.2 Choosing the ring melody

The base and each handset can ring with a different melody. To set the base melody:

- /OK | **1** Enter the menu
  | **2** Select “SETUP” and confirm.
  | **3** Select “BASE MELODY” and confirm.
  | **4** Select a melody (1 to 5).
/OK  | **5** Confirm or return to the previous menu.

7.3 Changing the PIN code

Certain functions are only available to users who know the PIN code. By default the PIN code is 0000. To change the PIN code:

- | | |
|-----------|--|
| ↵/OK | 1 Enter the menu |
| ▲▼ ↵/OK | 2 Select "SETUP" and confirm. |
| ▲▼ ↵/OK | 3 Select "PIN CODE" and confirm. |
| ☐☐☐☐ ↵/OK | 4 Enter the old 4 figure PIN code and confirm. |
| ☐☐☐☐ ↵/OK | 5 Enter a new 4 figure PIN code and confirm. |
| ☐☐☐☐ ↵/OK | 6 Enter the new PIN code a second time and confirm. |

7.4 Setting the dialing mode

There are two types of dialing mode: DTMF/Tone dialing (most common) and pulse dialing (for older installations).

To change the dialing mode:

- | | |
|---------|---|
| ↵/OK | 1 Enter the menu |
| ▲▼ ↵/OK | 2 Select "SETUP" and confirm. |
| ▲▼ ↵/OK | 3 Select "DIAL MODE" and confirm. |
| ▲▼ ↵/OK | 4 Select the dialing mode and confirm. |

7.5 Flash time duration

Press the flash key 'R' (key 7 - picture 2C Handset) to use certain services on your external line such as "call waiting" (if your phone company offers this feature); or to transfer calls if you use a telephone exchange (PABX). The Flash key 'R' is a brief interruption of the line. You can set the flash time to 100ms or 250ms.

- | | |
|---------|--|
| ↵/OK | 1 Enter the menu |
| ▲▼ ↵/OK | 2 Select "SETUP" and confirm. |
| ▲▼ ↵/OK | 3 Select "RECALL" and confirm. |
| ▲▼ ↵/OK | 4 Choose "RECALL1" for short flash time (100ms) or "RECALL2" for long flash time (250ms) and confirm. |

8 Managing multiple handsets

8.1 Adding a new handset



Only needed when you have deregistered a handset or when you bought a new one.

You can register new handsets on the base if these handsets support the DECT GAP protocol. The base can support a maximum of 5 handsets. If you already have 5 handsets, and you wish to add another one or change one handset, you must first delete a handset, then associate the new handset.

Putting the base into registration mode:

- | | |
|-----|--|
| •)) | 1 Press and hold the paging key on the base for 6 seconds. The base will then emit a beep tone. |
|-----|--|

Register the new handset:

If your additional handset is a Topcom Balance

- | | |
|---|--|
| <p>↵/OK</p> <p>▲▼ ↵/OK</p> <p>▲▼ ↵/OK</p> <p>☐☐☐ ↵/OK</p> <p>☐☐☐ ↵/OK</p> <p>↵/OK ☒</p> | <p>2 Enter the menu</p> <p>3 Select "REGISTER" and confirm.</p> <p>4 Select "REG BASE" and confirm.</p> <p>5 Enter the number of the base to be associated with the handset (1-4) and confirm. (The flashing numbers are already in use.)</p> <p>6 Enter the base PIN code (0000 by default) and confirm.</p> <p>The handset will start searching for the DECT base. If the handset has located the base, it will display the base identification number.</p> <p>7 Confirm or stop.</p> <p>If the handset does not locate the base, it will return to the standby mode after a few seconds. Try again by changing the base number and check that you are not in an environment with interference. Move closer to the base.</p> |
|---|--|

If your handset is another model

After starting the registration procedure on the base, refer to the handset manual to find out how to register the handset. The handset must be GAP compatible.

The icon  and the text "NOT REG" flashes on the display when the handset is not associated with the base.

When a handset is associated with a base, it is attributed a handset number by the base. It is this number that is displayed on the handset after the name and must be used for internal calls.



DECT GAP Profile only guarantees that basic calling-functions will work correctly between different brands/types. There's a possibility that certain services (like CLIP) will not work correctly.

8.2 Removing a handset



This procedure needs to be carried out on a different handset than the one you want to remove.

- | | |
|--|---|
| <p>↵/OK</p> <p>▲▼ ↵/OK</p> <p>▲▼ ↵/OK</p> <p>☐☐☐ ↵/OK</p> <p>▲▼ ↵/OK</p> | <p>1 Enter the menu</p> <p>2 Select "SETUP" and confirm.</p> <p>3 Select "DEL HANDSET" and confirm.</p> <p>4 Enter the base PIN code (0000 by default) and confirm.</p> <p>5 Select the handset to be removed and confirm.</p> |
|--|---|

8.3 Setting up a handset on another base

If you want to use a Topcom Balance handset with a base of another model. The base must be GAP compatible.

- | | |
|---|--|
| <p>↵/OK</p> <p>▲▼ ↵/OK</p> <p>▲▼ ↵/OK</p> <p>☐☐☐ ↵/OK</p> <p>☐☐☐ ↵/OK</p> | <p>1 Put the base in registration mode, refer to the base manual.</p> <p>2 Enter the menu</p> <p>3 Select "REGISTER" and confirm.</p> <p>4 Select "REG BASE" and confirm.</p> <p>5 Enter the number of the base to be associated with the handset and confirm.</p> <p>6 Enter the base PIN code and confirm.</p> |
|---|--|

- ⇒/OK  | The handset will start searching for the DECT base. If the handset has located the base, it will display the base identification number.
- ⇒/OK  | **7** Confirm or stop.

8.4 Selecting a base

You can switch your handset between bases. The handsets can be registered up to 4 bases simultaneously. When selecting the base, the current selected base is indicated by a blinking base number.

If you select “AUTO” the handset will automatically search for another base when you are out of range. The handset must first be registered with each base individually.

- ⇒/OK | **1** Enter the menu
- ▲▼ ⇒/OK | **2** Select “REGISTER” and confirm.
- ▲▼ ⇒/OK | **3** Select “SELECT BASE” and confirm.
- ▲▼ ⇒/OK | **4** Select a base or select “AUTO” and confirm.



When you have activated Automatic base selection and the handset is out of range on the current base, the handset will only search for the strongest base in standby (not during communication).

9 SMS

You can send and receive SMS with your Topcom Balance telephone. This section tells you how to use the SMS feature. You can store a total of 15 SMS messages sent and received, each with up to 160 characters.





Before sending and receiving SMS text messages you need to set the telephone number of your Network's SMS centre for outgoing and incoming messages (See “SMS service centre numbers”).

9.1 How to write an SMS

The method is the same as entering a name in the phonebook (See “3.15 Using the alphanumerical keypad”).

To enter a space press ‘1’.

9.2 Sending an SMS

- ⇒/OK | **1** Enter the menu
- ▲▼ ⇒/OK | **2** Select “SMS” and confirm.
- ▲▼ ⇒/OK | **3** Select “WRITE” and confirm.
-  ⇒/OK | **4** Start writing the message and confirm.
-  ⇒/OK | **5** Enter the telephone number and confirm to send the message.
- The SMS will be sent out automatically.

9.3 Read and view the list of received messages (Inbox)

Your Topcom Balance display indicates the number of new messages you have received.  is shown on the screen. The SMS LED on the base is blinking. A beep indicates you have just received a new message.

/OK

When the number of new messages is indicated on the display.

1 Press the OK key. The telephone number of the most recent message is listed first.

/OK

When the number of new messages is not displayed.

1 Enter the menu

/OK

2 Select "SMS" and confirm.

/OK

3 Select "INBOX" and confirm.

The telephone number of the most recent message is listed first.

/OK

Scroll through all messages and press OK to read the message.

Messages with "*" before the telephone number are unread messages.

/OK

Scroll through the whole message and press OK when the whole message is read.

Scroll to select one of the next options:

Reply: Edit the message using the alphanumeric keypad and save it.

Forward: Forward the stored message to another user. Follow the same instructions as for sending an SMS message (See "9.2 Sending an SMS").

Delete ?: Delete the message. Press OK again to confirm.

Details: To see the phonenumber, date and time of the message. Press OK to confirm.



Press the mute key to return to the inbox menu

9.4 Multiple users

With your Topcom Balance telephone you can register up to 5 handsets on one base. Each handset has its own handset number (1-5) which is also the terminal number to send Personal messages. All handset have standard terminal number '0' as well. In order to receive personal SMS messages, you must give your correspondents the user Terminal Number that they need to add to your standard telephonenumber (See below). For example, when you have a 2nd handset (Handset 2) this handset will have terminal number = 2.

If no terminal number is add to you telephone number or '0', all handset will receive these messages.

You can change the terminal number to another one but only from 6-9 (See "Setting the terminal number").

Receiving personal user SMS



Your correspondents will need to add your Terminal Number to your telephone number when they want to send personal SMS.

E.g. If your personal Terminal Number is "1" and your telephone number is 123456789, your correspondents should send their SMS messages to: 1234567891! This is the number you need to remember and give to your correspondents.

Reading personal user SMS

When a new message comes in, your Topcom Balance emits a beep. The screen shows  and the number of new messages.

/OK

Press the OK key

In the SMS list, private messages are flagged with the key icon  on the screen.

OR

/OK

1 Enter the menu

 /OK

2 Select "SMS" and confirm.

 /OK

3 Select "PERSONAL SMS" and confirm. The telephone number of the most recent message is listed first.

9.5 SMS settings

Set SMS alert tone ON/OFF

Your handset can play a melody to announce a new text message.

/OK

1 Enter the menu

 /OK

2 Select "SMS" and confirm.

 /OK

3 Select "SMS SETTINGS" and confirm.

 /OK

4 Select "MSG ALERT" and confirm.

 /OK

5 Select "ON" or "OFF" and confirm.

 /OK

6 Select the desired melody and confirm and go back to previous menu.

SMS service centre numbers

To send and receive SMS text messages you need the telephone number of your Network's SMS centre. These numbers have been pre-loaded into the Topcom Balance. If you accidentally delete the SEND or RECEIVE SMS service centre numbers you will need to re-enter them in order for your SMS service to work.

The Topcom Balance can store 2 SEND SMS service centre numbers and 2 RECEIVING SMS service centre numbers.

To set the SMS sending centres numbers

/OK

1 Enter the menu

 /OK

2 Select "SMS" and confirm.

 /OK

3 Select "SMS SETTINGS" and confirm.

 /OK

4 Select "SEND CENTRE" and confirm.

 /OK

5 Select "SEND 1" or "SEND 2" and confirm.

  /OK

6 Enter the telephone number of the SMS server

To set the SMS receiving centres numbers

/OK

1 Enter the menu

 /OK

2 Select "SMS" and confirm.

 /OK

3 Select "SMS SETTINGS" and confirm.

 /OK

4 Select "RCV CENTRE" and confirm.

 /OK

5 Select "RECEIVE 1" or "RECEIVE 2" and confirm.

  /OK

6 Enter the telephone number of the SMS server

Select the SMS centre to send SMS

Because you can set 2 SMS sending centres, you have to select one of both before sending you messages:

- | | | |
|---------|----------|--|
| ↵/OK | 1 | Enter the menu |
| ▲▼ ↵/OK | 2 | Select "SMS" and confirm. |
| ▲▼ ↵/OK | 3 | Select "SMS SETTINGS" and confirm. |
| ▲▼ ↵/OK | 4 | Select "SEND SERVICE" and confirm. |
| ▲▼ ↵/OK | 5 | Select "SEND 1" or "SEND 2" and confirm. |

Setting the terminal number

Each handset has terminal number '0' and terminal number = handset number (1-5). You can change the terminal number to another number (6-9) if needed:

- | | | |
|---------|----------|--|
| ↵/OK | 1 | Enter the menu |
| ▲▼ ↵/OK | 2 | Select "SMS" and confirm. |
| ▲▼ ↵/OK | 3 | Select "SMS SETTINGS" and confirm. |
| ▲▼ ↵/OK | 4 | Select "TERMINAL NO" and confirm. |
| ⊗ ☐☐☐ | 5 | Delete the old terminal number and enter the new one (0, 6-9). |
| ↵/OK | 6 | Press OK to confirm. |

Memory full

When the memory is full, you get the screen message "Memory Full". You can no longer send or receive SMSs. To continue to receive SMSs, you can delete some or all of the messages. To delete all the messages stored in the "INBOX" or "PERSONAL SMS":

- | | | |
|---------|----------|---|
| ↵/OK | 1 | Enter the menu |
| ▲▼ ↵/OK | 2 | Select "SMS" and confirm. |
| ▲▼ ↵/OK | 3 | Select "SMS SETTINGS" and confirm. |
| ▲▼ ↵/OK | 4 | Select "DELETE ALL" and confirm. |
| ▲▼ ↵/OK | 5 | Select "INBOX" or "PERSONAL SMS" and confirm. |
| | 6 | "CONFORM ?" appears. |
| ↵/OK ⊗ | 7 | Confirm or cancel. |

10 Troubleshooting

Symptom	Possible cause	Solution
No display	Batteries uncharged	Check the position of the batteries
		Recharge the batteries
	Handset turned off	Turn on the handset
No tone	Telephone cord badly connected	Check the telephone cord connection
	The line is occupied by another handset	Wait until the other handset hangs up
The icon  flashes	Handset out of range	Bring the handset closer to the base
	The base has no power supply	Check the mains connection to the base
	The handset is not registered on the base	Register the handset on the base
Base or handset do not ring	The ringing volume is off or low	Adjust the ringing volume
Tone is good, but there is no communication	The dialing mode is wrong	Adjust the dialing mode (pulse/tone)
Not possible to transfer a call on PABX	The flash time is too short or too long	Change the flash time
Telephone does not react when pressing the keys	Manipulation error	Remove the batteries and put them back in place

11 Technical data Technical characteristics

Standard	DECT (Digital Enhanced Cordless Telecommunications) GAP (Generic Access Profile)
Frequency range	1880 MHz to 1900 MHz
Number of channels	120 duplex channels
Modulation	GFSK
Speech coding	32 kbit/s
Emission power	10 mW (average power per channel)
Range	maximum 300m in open space / 10-50m in-house
Number of handsets	Up to 5
Base power supply	230V / 50 Hz / 7,5V DC 300mA
Handset Batteries	2 rechargeable batteries AAA, NiMh 1,2V, 550mAh
Handset autonomy	200 hours in standby
Handset talk time	10 hours
Normal conditions of use	+5 °C to +45 °C
Dialing mode	Pulse / Tone
Flash time	100 or 250 ms

12 Topcom Warranty

12.1 Warranty period

The Topcom units have a 24-month warranty period. The warranty period starts on the day the new unit is purchased. There is no warranty on standard or rechargeable batteries (AA/AAA type). Consumables or defects causing a negligible effect on operation or value of the equipment are not covered.

The warranty has to be proven by presentation of the original or copy of the purchase receipt, on which the date of purchase and the unit-model are indicated.

12.2 Warranty handling

A faulty unit needs to be returned to a Topcom service centre including a valid purchase note and a filled in service card.

If the unit develops a fault during the warranty period, Topcom or its officially appointed service centre will repair any defects caused by material or manufacturing faults free of charge, by either repairing or exchanging the faulty units or parts of the faulty units. In case of replacement, colour and model can be different from the original purchased unit.

The initial purchase date shall determine the start of the warranty period. The warranty period is not extended if the unit is exchanged or repaired by Topcom or its appointed service centre.

12.3 Warranty exclusions

Damage or defects caused by incorrect treatment or operation and damage resulting from use of non-original parts or accessories are not covered by the warranty.

The warranty does not cover damage caused by outside factors, such as lightning, water and fire, nor any damage caused during transportation. No warranty can be claimed if the serial number on the units has been changed, removed or rendered illegible.

Any warranty claims will be invalid if the unit has been repaired, altered or modified by the buyer. This appliance may only be used with rechargeable batteries. If you want to replace the originally included batteries, please check whether the batteries you use are suitable and rechargeable. Alkaline batteries may under NO circumstances be used in the handsets. If you use Alkaline batteries and place the handset on the basis, the batteries will heat up and may explode. Any damage which may be caused cannot be recovered from the manufacturer and the damage thus caused to the appliance is not covered by the warranty conditions. Any repairs will be charged to you.

13 Disposal of the device (environment)



At the end of the product lifecycle, you should not throw this product into the normal household garbage but bring the product to a collection point for the recycling of electrical and electronic equipments. The symbol on the product, user guide and/or box indicate this.

Some of the product materials can be re-used if you bring them to a recycling point.

By re-using some parts or raw materials from used products you make an important contribution to the protection of the environment. Please contact your local authorities in case you need more information on the collection points in your area.

14 Cleaning

Clean the telephone with a slightly damp cloth or with an anti-static cloth. Never use cleaning agents or abrasive solvents.

DECLARATION OF CONFORMITY

We manufacturer, Topcom Europe Nv, Grauwmeer 17, 3001 Heverlee, Belgium, declare that our product :

Type: Wireless Telephone Device (DECT)

Model: Balance

Class of equipment: Class 1

is in compliance with the essential requirements and other relevant provisions of the R&TTE directive 1999/5/EC and carries the CE mark accordingly.

Supplementary information:

The product complies with the requirements of:

- EN 60950-1 : 2006
- EN 301489-01 V1.6.1 : 2002
- EN 301489-06 V1.2.1 : 2002
- EN 301406 V1.5.1 : 2003

Date: 25/6/2008

Place: Heverlee, Belgium

Name: Verheyden Geert

Function: Technical Director

Signature:



European contact: Topcom Europe Nv, R&D department, Research Park, Grauwmeer 17, 3001 Heverlee, Belgium. Tel : +32 16 398920, Fax : +32 16 398939

SERVICE RETURN CARD - RÜCKSENDEKARTE -
CARTE DE RETOUR SERVICE - RETOURFICHE

RETURN WITH YOUR DEFECT PRODUCT

Name/Vorname/Prénom/Naam:

Surname/Familiennaam/Nom/Familiennaam:

Street/Straße/Rue/Straat:

Nr./N°:

Box/Postfach/Boîte/Postbus:

Location/Ort./Lieu/Plaats:

Post code/Postleitzahl/Code Postal/Postcode:

Country/Land/Pays/Land:

Tel./Tél.:

E-mail:

Model name/Modellbezeichnung/Nom du modèle/Modelnaam:

Serial Nr./Seriennummer/N° série/Seriennummer:

Purchase date/Kaufdatum/Date d'achat/Aankoopdatum:

 - - (DD/MM/YYYY) - (TT/MM/JJJJ)

Fault description/Beschreibung des Defekts/Description de la panne/Beschrijving defect:

(Original Proof of Purchase has to be attached to this return card to be valid for warranty)



Model name/Modellbezeichnung/Nom du modèle/Modelnaam:

Serial Nr./Seriennummer/N° série/Seriennummer:

Purchase date/Kaufdatum/Date d'achat/Aankoopdatum:

 - - (DD/MM/YYYY) - (TT/MM/JJJJ)

Fault description/Beschreibung des Defekts/Description de la panne/Beschrijving defect:



TOPCOM[®]

BALANCE

**visit our website
www.topcom.net**